

Check-List for Lifting,-Rolling,- and Loading System type 1350



for quotation for purchase order

Company:
 Address: Contact:
 Post Code / City: Department:
 Phone: Fax: email

1. Container / shelter

Dimension (over corner castings)

Height H = mm

Width B = mm

Length L = mm

Corner castings: ISO

other (attach drawing please)

grav. center: central

other

Coordinates: Dist. x_s = mm

Dist. y_s = mm

Dist. z_s = mm

Net weight kg

max. load kg

Attachments for container

(attach drawing please)

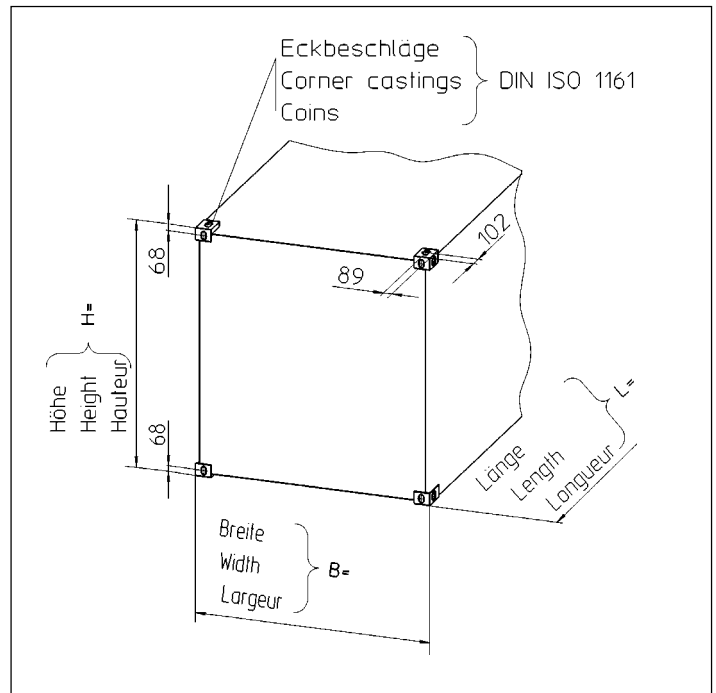

2. Type of plane / types of planes

3. Mission military civil

3.1 Way of loading:

inclined rampe max. rolling way (level loading): m

horizontal rampe max. inclination of ramp: °

frequency: 1 / day / day

3.2 Lifting / Lowering

3.2.1 Vehicle-type: max. height without load: mm

3.2.2 space between cargo area / drivers cabine to container: mm

3.2.3 others: max. height lower edge container to floor: mm

3.2.4 max. lift (standard = 1750 mm)

3.3 Stand operation

3.3.1 container remains at Lifting,- Rolling,- and Loading System: Yes No

If Yes, max. height lower edge container to ground: mm

3.3.2 Soil conditions

3.3.3 Stand time (without interrupt) max.: h

67-1

haacon hebetchnik gmbh
 Josef-Haamann-Str. 6
 D-97896 Freudenberg/Main

Tel: + 49 (0) 93 75/84-0
 Fax: + 49 (0) 93 75/84-86
 e-mail: engineering@haacon.de
 Internet: http://www.haacon.com

3.4 Temperature range

during operation: from - °C to +°C
storage: from - °C to +°C

4. Options

4.1 Drive

- manually
- 400 V AC
- 230 V AC
- 24/28 V DC

4.2 Wheel set

- with manual brake
- with automatic brake (in case of rope rupture)

5. Coating

Cathodic anti-corrosion coating and

Surface coating

- RAL 6031 (NATO-Green)
- BS 381 C285 (British Nato Green)
- RAL
- other (attach details please)

6. Packing

- Standard case (only transport case)
- other

7. Documents

- | | |
|--------------------------------------|--------------------------------------|
| Type plate: | Operating instructions: |
| <input type="checkbox"/> German | <input type="checkbox"/> German |
| <input type="checkbox"/> English | <input type="checkbox"/> English |
| <input type="checkbox"/> French | <input type="checkbox"/> French |
| <input type="checkbox"/> other | <input type="checkbox"/> other |

8. Declaration of conformity

- Yes No

.....
Date

.....
Signature

.....
Company stamp