

Checklist for designing a sluice gate drive

For a quotation kindly fill in at least the details marked with *.

Company:

Street / No.:..... Contact.....

Postcode / Place:..... Department

Phone. Fax..... Email.....

1. Dimension definition

Please define the dimensions for your project using the sketch and enter them in the following table. If the reinforcement systems are different, please complete one checklist per sluice gate drive.

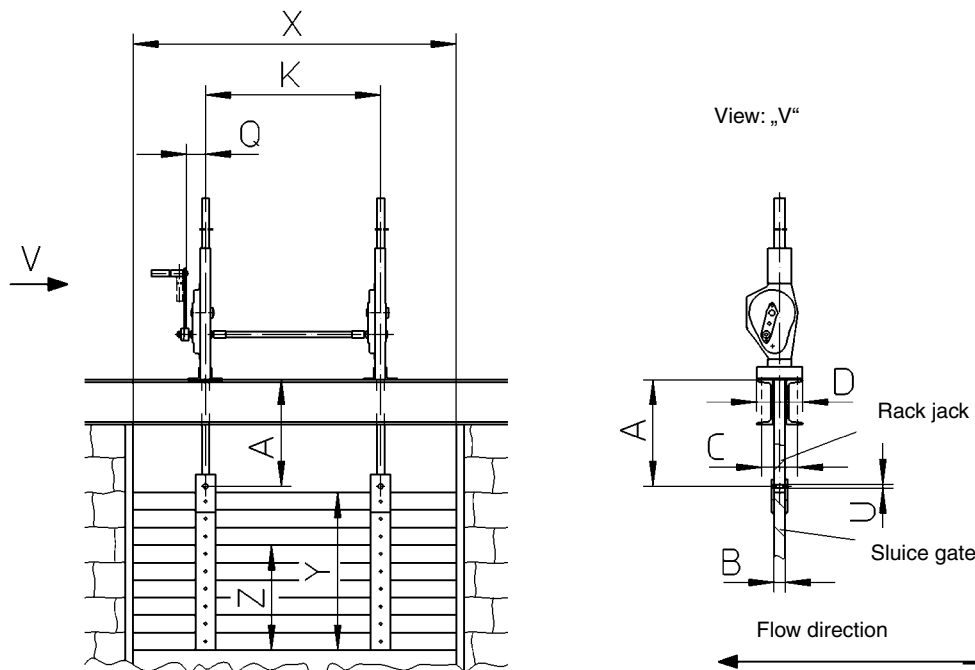

* Required number of sluice gate drives:.....

* 1.1 Sluice gate guide:

- Steel/Wood
- Steel/Steel
- Steel/Plastic
- Roller guide

1.2 Material for sluice gate: Wood Steel Thickness: mm

* 1.3 Sluice gate width X = mm

* 1.4 Sluice gate height Y = mm

* 1.4.1 Water storage level Z = mm

* 1.5 Total weight of the sluice gate G = kg

1.6 Winch spacing for double sluice gate drive K = mm

* 1.7 Dimension A (sluice gate, top) A = mm

* 1.8 Required lift H = mm

1.9 Dimension C C = mm

1.10 Dimension D D = mm

1.11 Bore hole diameter U = mm

34-0

haacon hebeteknik gmbh
 Josef-Haamann-Str. 6
 D-97896 Freudenberg/Main

Tel: + 49 (0) 93 75/84-0
 Fax: + 49 (0) 93 75/84-86
 e-mail: hebeteknik@haacon.de
 Internet: http://www.haaccon.com

2. * Drive

Please tick the checkbox

- 2.1 Manual operation, lateral
- 2.2 Manual operation, by angular gear
 - Fixed crank handle
 - Removable crank handle
 - Crankshaft extension

Please specify dimension Q mm

2.3 Electric drive with emergency crank handle for current type:
incl. stroke limit switches and load limiter

- 400 V three-phase current
- 230 V AC
- 24 V DC

2.4 Control

3. * Frequency of use

- 3.1 Actuation up to 10 x per annum
- 3.2 Actuation up to 100 x per annum
- 3.3 Actuation up to 500 x per annum
- 3.4 Continuous operation: On-Off mode > 10 x per day
- 3.5 Controlled operation

4. Installation situation

4.1 Application or use

.....

4.2 Direction of bore hole "U" in the flow direction

4.3 Direction of bore hole "U" perpendicular to the flow direction

5. * Accessories

5.1 Rack covered with fixed protective tube

5.2 Rack with protective cap (rises with rack)

5.3 Surface protection: KTL coating Galvanized Powder coated RAL 9005
 other

6. Sluice gate ratio for sluice gate drive design

Sluice gate ratio = $Y/X = \frac{\quad}{\quad} = \quad$

from which we obtain: $Y/X \geq 1.5 =$ Single sluice gate drive

$Y/X < 1.5 =$ Double sluice gate drive

7. Required pulling force F

$$F = [\mu \times Y \times (Z - Y/2) \times X + G] \times S \times 10 = (N)$$

Y = Height of sluice gate

Z = Total static height in dm. If the storage level is less than the sluice gate height put in this value

X = Width of sluice gate in dm

G = Total weight of sluice gate in kg

S = Safety factor (we recommend S = 2)

μ = Coefficient of friction (experience values) for: Wood/Steel = 0.45, Steel/Steel = 0.3, Steel/Plastic = 0.25, For rollers = 0.15